



Selection: Semi-hermetic Screw Compressors HS

Input Values

Compressor model	HSN6451-40	Operating mode	Economizer
Refrigerant	R404A	Power supply	400V-3-50Hz
Reference temperature	Dew point temp.	Useful superheat	100%
Liq. subc. (in condenser)	0 K	Additional cooling	Automatic
Auto. subcooling	Auto	Max. discharge gas temp.	80,0 °C
Suct. gas superheat	10,00 K		

Result

Q [W]	Cooling capacity	mHP [kg/h]	Mass flow HP
P [kW]	Power input	Qac [kW]	Additional cooling
I [A]	Current	tcu [°C]	Liquid temp.
COP [-]	COP/EER	pm [bar(a)]	ECO pressure
mLP [kg/h]	Mass flow LP	Qsc [kW]	sub cooler capacity (ECO)

tc	to	-15°C	-20°C	-25°C	-30°C	-35°C	-40°C	-45°C	-50°C
30°C	Q [W]	91330	76965	64196	52893	42935	34205	26592	19994
	P [kW]	30,8	29,7	28,6	27,6	26,5	25,5	24,3	23,1
	I [A]	51,7	50,2	48,8	47,4	45,9	44,5	42,9	41,3
	COP [-]	2,97	2,59	2,24	1,92	1,62	1,34	1,09	0,87
	mLP [kg/h]	2219	1837	1504	1217	970	758	579	427
	mHP [kg/h]	2634	2265	1929	1625	1349	1100	876	675
	Qac [kW]	--	--	--	--	--	1,12	4,27	7,07
	tcu [°C]	12,94	9,00	4,91	0,66	-3,73	-8,27	-12,94	-17,73
	pm [bar(a)]	6,63	5,85	5,12	4,44	3,81	3,23	2,71	2,24
	Qsc [kW]	15,39	15,63	15,23	14,33	13,05	11,50	9,78	7,97
40°C	Q [W]	86162	72550	60468	49786	40383	32152	24994	--
	P [kW]	37,7	36,7	35,6	34,4	33,2	31,8	30,5	30,5
	I [A]	61,5	60,0	58,4	56,8	55,0	53,2	51,3	51,3
	COP [-]	2,28	1,98	1,70	1,45	1,22	1,01	0,82	0,82
	mLP [kg/h]	2187	1804	1473	1187	942	733	557	557
	mHP [kg/h]	2822	2429	2071	1746	1452	1186	948	948
	Qac [kW]	--	--	--	1,46	4,78	7,82	10,53	10,53
	tcu [°C]	17,28	13,24	8,99	4,54	-0,11	-4,94	-9,94	-9,94
	pm [bar(a)]	7,56	6,69	5,85	5,06	4,33	3,65	3,04	3,04
	Qsc [kW]	21,1	20,4	19,14	17,50	15,58	13,48	11,30	11,30
50°C	Q [W]	--	--	--	--	36413	28770	22107	--
	P [kW]	--	--	--	--	42,0	40,3	38,5	--
	I [A]	--	--	--	--	67,9	65,4	62,6	--
	COP [-]	--	--	--	--	0,87	0,71	0,57	--
	mLP [kg/h]	--	--	--	--	883	679	507	--
	mHP [kg/h]	--	--	--	--	1543	1257	998	--
	Qac [kW]	--	--	--	--	15,67	18,03	19,95	--
	tcu [°C]	--	--	--	--	4,17	-1,12	-6,64	--
	pm [bar(a)]	--	--	--	--	5,00	4,18	3,43	--
	Qsc [kW]	--	--	--	--	17,42	14,77	12,10	--

-- No calculation possible (see message in single point selection)

*According to EN12900 (10K suction gas superheat, liquid subcooling in Economiser with 5K temperature difference)

Application Limits ECO HSN6451-40

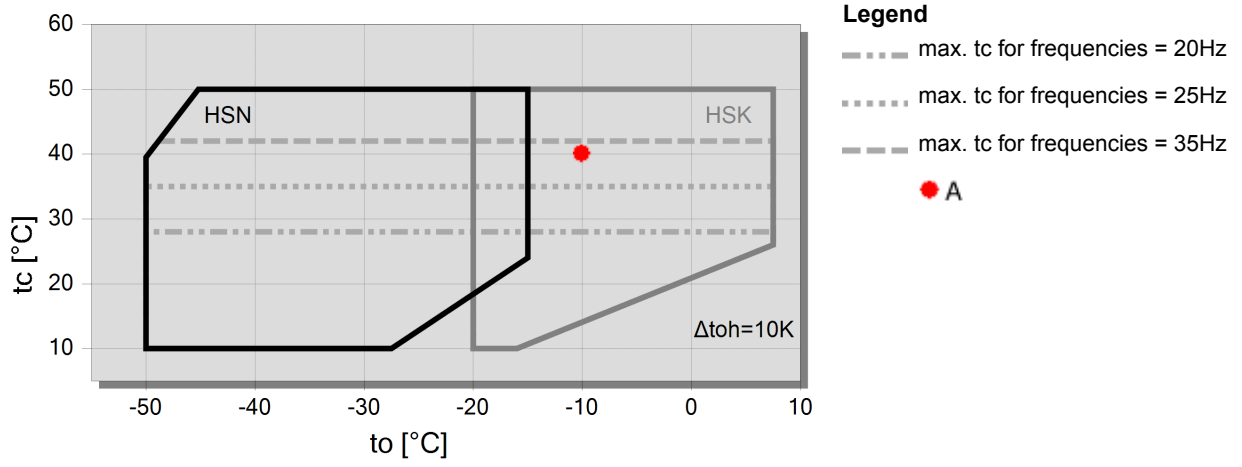



Technical Data: HSN6451-40

Dimensions and Connections

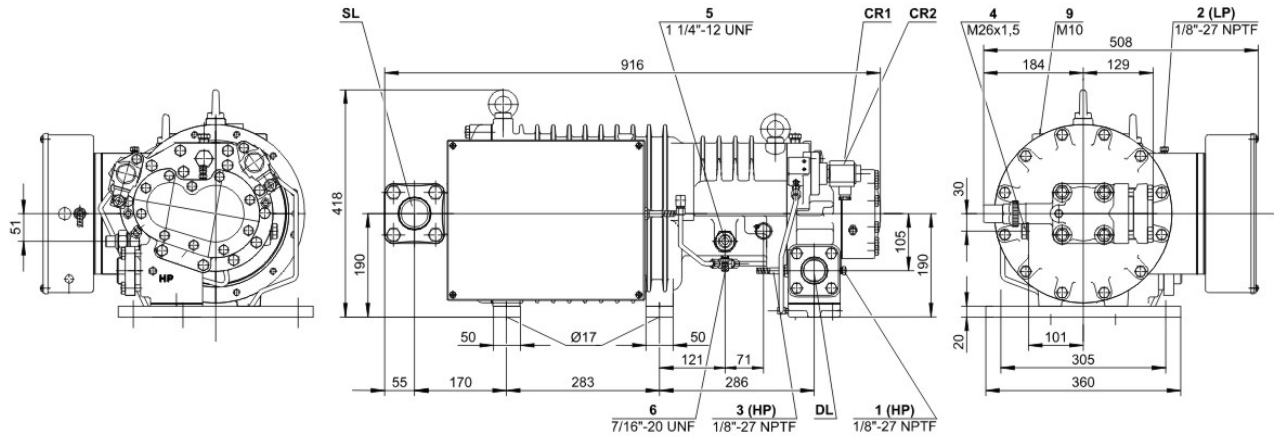

Technical Data

Technical Data

Displacement (2900 RPM 50 Hz)	140 m ³ /h
Displacement (3500 RPM 60 Hz)	168 m ³ /h
Weight	234 kg
Max. pressure (LP/HP)	19 / 28 bar
Connection suction line	54 mm - 2 1/8"
Connection discharge line	42 mm - 1 5/8"
Adapter/shut-off valve for ECO	22 mm - 7/8" (Option)
Oil type R22	B150SH, B100 (Option)
Oil type R134a/R404A/R507A/R407A/R407F	BSE170 (Option)
Oil type R448A/R449A	BSE170 (Option)

Motor data

Motor voltage (more on request)	380-415V PW-3-50Hz
Max operating current	65.0 A
Starting current (Rotor locked)	187.0 A D / 313.0 A DD
Max. Power input	42,0 kW

Extent of delivery (Standard)

Discharge gas temperature sensor	Standard
Start unloading	Standard
Oil flow control	SE-B2 (Standard)
Motor protection	SE-E1 (Standard), SE-E3 (Standard for 660-690V)
Suction shut-off valve	Standard
Capacity control	100-75-50% (Standard)
Enclosure class	IP54

Available Options

Discharge shut-off valve	Option
ECO connection with shut-off valve	Option
Motor protection	SE-i1 (200-690V)

Sound measurement

Sound power level (-35°C / 40°C)	86,5 dB(A)
Sound pressure level @ 1m (-35°C / 40°C)	78,5 dB(A)



Semi-hermetic Screw Compressors HS

HSK = Application for air-conditioning and medium temperature cooling.

HSN = Application for low temperature cooling.

Notes regarding application limits (see "Limits")

- * Ranges are valid for standard operation and at full-load conditions.
- * With high pressure conditions, part-load operation is partly limited (see application limits in applications manual SH-100).
- * With Economizer operation the maximum admissible evaporation temperature is shifted by 10 K downward (otherwise there is a danger of excessive compression and overload of the motor because of a higher mass flow). At pull-down conditions from higher evaporation temperatures, the ECO injection must remain closed until the evaporation temperature is below the maximum admissible value and a stable operation is achieved (e.g. control of the ECO solenoid valve by means of a low pressure cut-out). The use of the ECO-system with higher evaporation temperatures requires individual consultation with Bitzer.

HS 64/74

- * Capacity control with ECO operation at the same time is limited to one single regulating step (CR 75 %). At CR 50 % the ECO injection should be closed.

Data for sound emission

Data are based on 50 Hz application (IP-units 60 Hz) and R404A.

Sound pressure level: values are based on open air test sites with semi-spherical sound emissions at 1 meter distance. For further information see Technical Information "Sound Data".

Legend of connection positions according to "Dimensions":

- 1 High pressure connection (HP)
 - 1a Additional high pressure connection
 - 1b Connection for high pressure transmitter (HP)
 - 2 Low pressure connection (LP)
 - 2a Additional low pressure transmitter (LP)
 - 2b Connection for low pressure transmitter (LP)
 - 3 Discharge gas temperature sensor connection (HP)
 - 4 Connection for economizer (ECO)
 - HS.85: ECO valve with connection pipe (option)
 - HS.95, OS.85, OS.95: ECO valve (option)
 - 5 Oil injection connection
 - 6 Oil pressure connection for HS.85 and OS.85:
 - Oil drain (compressor housing)
 - 7 Oil drain (motor housing)
 - 7a Oil drain (suction gas filter)
 - 7b Oil drain out of shaft seal (maintenance connection)
 - 7c Oil drain tube (shaft seal)
 - 8 Threaded bore for foot fastening
 - 9 Threaded bore for pipe support (ECO and LI line)
 - 10 Maintenance connection (oil filter)
 - 11 Oil drain (oil filter)
 - 12 Monitoring of oil stop valve
 - 13 Oil filter monitoring
 - 14 Oil flow switch
 - 15 Earth screw for housing
 - 16 Pressure relief (oil filter chamber)
 - 17 Maintenance connection for shaft seal
 - 18 Liquid injection (LI)
 - 19 Compressor module
 - 20 Slider position indicator
 - 21 Oil level switch
 - 22 Connection for oil pressure transmitter
 - 23 Connection for oil and gas return (for systems with flooded evaporator adapter optional)
 - 24 Access to oil circulation restrictor
 - SL Suction gas line
 - DL Discharge gas line
- Dimensions can show tolerances according to EN ISO 13920-B.